

Noise Feasibility Study

Proposed Mixed-Use/Residential Development

1127 Garrison Road

Fort Erie, Ontario

Prepared for:

Wolf Pack Build Inc.
147 Rivermede
Vaughan, Ontario
L4K 3M4

Prepared by

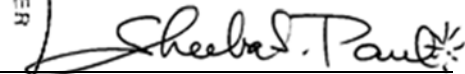

Sheeba Paul, MEng, PEng

October 6, 2023

HGC Project Number: 02200486

Table of Contents

1	Introduction & Summary	1
2	Site Description & Noise Sources.....	2
3	Noise Level Criteria.....	2
3.1	Road Traffic Noise	2
4	Traffic Noise Assessment	4
4.1	Road Traffic Data	4
4.2	Traffic Noise Predictions.....	4
5	Traffic Noise Recommendations	5
5.1	Outdoor Living Areas.....	5
5.2	Indoor Living Areas & Ventilation Requirements	6
5.3	Building Façade Constructions.....	6
6	Warning Clauses	8
7	Summary & Recommendations	9
7.1	Implementation.....	10

Figure 1: Key Plan

Figure 2: Proposed Site Plan Showing Prediction Locations

Figure 3: Proposed Site Plan Showing Ventilation Requirements

Appendix A: Road Traffic Data

Appendix B: Sample STAMSON 5.04 Output

Appendix C: Supporting Drawings

1 Introduction & Summary

HGC Engineering was retained by Wolf Pack Build Inc. to conduct a noise feasibility study for a proposed mixed-use/residential development located at 1127 Garrison Road, in Fort Erie, Ontario. The proposed development will consist of a 3-storey mixed-use building and three residential buildings. The study is required by the Region of Niagara as part of the planning and approvals process.

The primary source of noise impacting the site was determined to be road traffic on Garrison Road. Road traffic data was obtained from the Region of Niagara. Relevant traffic data was used to predict future traffic sound levels at the proposed mixed-use/residential development. The predicted sound levels were compared to the guidelines of the Ministry of Environment, Conservation and Parks (MECP) and the Region to develop noise control recommendations.

The sound level predictions indicate that the future road traffic sound levels will exceed MECP guidelines at the proposed buildings. Central air conditioning is required for the dwelling units in Block A. Upgraded glazing constructions are required for the north façade of units in Block A with direct exposure to Garrison Road. Forced-air ventilation systems with ducts sized to accommodate the future installation for central air conditioning by the occupant or an alternative means of ventilation to open windows are required for units in Blocks B and C further from Garrison Road. Warning clauses are recommended to inform future residents of the proximity to existing and proposed commercial uses, existing institutional uses and the traffic noise excesses at the proposed buildings.

When detailed floor plans and building elevations are available for the Block closest to Garrison Road, a detailed noise study should be completed to refine acoustic recommendations for the proposed building. In addition, an acoustical consultant should review the mechanical drawings and details of demising constructions, when available, to help ensure that the noise impact of the development on itself, are maintained within acceptable levels.

2 Site Description & Noise Sources

The proposed development is located at the south side of Garrison Road, specifically at 1127 Garrison Road in Fort Erie, Ontario. Figure 1 shows a key plan of the subject site. A site plan prepared by Organica Studio + Inc. dated 2023-09-19 is shown in Figure 2. The proposed development will include a 3-storey mixed-use building, with commercial units on the ground floor and residential units on floors 2 and 3. The development also contains three 3-storey residential buildings and at grade parking. Appendix C includes the proposed floor plans and building elevations.

HGC Engineering personnel visited the site on July 5, 2022, to make observations of the acoustical environment. The primary source of noise impacting the site is road traffic on Garrison Road. The area surrounding the site is urban in nature. Garrison Road Public School is located north of the site and north of Garrison Road. West of the site is a Tim Hortons with a drive-through. There is approximately 80 m between the westerly site property line and the Tim Horton's property line. The property in between currently is vacant. During the site visit, traffic sounds dominated the site, nevertheless, a noise warning clause informing future owners and occupants of the proximity to institutional and commercial facilities is recommended as included in Section 6. There are no other significant stationary sources of noise within 500 m of the site

3 Noise Level Criteria

3.1 Road Traffic Noise

Guidelines for acceptable levels of road traffic noise applicable to residential developments are given in the MECP publication NPC-300, "Environmental Noise Guideline Stationary and Transportation Sources – Approval and Planning", release date October 21, 2013 and are listed in Table I below. The values in Table I are energy equivalent (average) sound levels [L_{EQ}] in units of A-weighted decibels [dBA].

Table I: MECP Road Traffic Noise Criteria [dBA]

Space	Daytime L_{EQ} (16 hour) Road	Nighttime L_{EQ} (8 hour) Road
Outdoor Living Areas	55 dBA	--
Inside Living/Dining Rooms	45 dBA	45 dBA
Inside Bedrooms	45 dBA	40 dBA

Daytime refers to the period between 07:00 and 23:00, while nighttime refers to the period between 23:00 and 07:00. The term "Outdoor Living Area" (OLA) is used in reference to an outdoor patio, a backyard, a terrace or other area where passive recreation is expected to occur. Small balconies are not considered OLAs for the purposes of assessment. Terraces greater than 4 m in depth (measured perpendicular to the building façade) are considered to be OLAs.

The guidelines in the MECP publication allow the daytime sound levels in an Outdoor Living Area to be exceeded by up to 5 dBA, without mitigation, if warning clauses are placed in the purchase and rental agreements to the property. Where OLA sound levels exceed 60 dBA, physical mitigation is required to reduce the OLA sound level to below 60 dBA and as close to 55 dBA as technically, economically, and administratively practical.

A central air conditioning system as an alternative means of ventilation to open windows is required for all dwellings where nighttime sound levels outside bedroom/living/dining room windows exceed 60 dBA or daytime sound levels outside bedroom/living/dining room windows exceed 65 dBA.

Forced-air ventilation with ducts sized to accommodate the future installation of air conditioning is required when nighttime sound levels at bedroom/living/dining room windows are in the range of 51 to 60 dBA or when daytime sound levels at bedroom/living/dining room windows are in the range of 56 to 65 dBA.

Building components such as walls, windows and doors must be designed to achieve indoor sound level criteria when the plane of the window nighttime sound level exceeds 60 dBA or the daytime sound level exceeds 65 dBA due to road traffic noise.

Warning clauses are required to notify future residents of possible excesses when nighttime sound levels exceed 50 dBA at the plane of the window and daytime sound levels exceed 55 dBA in the outdoor living area and at the plane of the window due to road traffic.

4 Traffic Noise Assessment

4.1 Road Traffic Data

Road traffic information for Garrison Road was obtained from the Region of Niagara, in the form of turning movement counts from 2019, and is provided in Appendix A. A commercial vehicle percentage of 3.77% was used in the analysis and was further split into 1.45% and 2.32% for medium and heavy trucks, respectively. A day/night split of 90%/10% was included in the calculations. The data was projected to the year 2043 using a 2.5%/year growth rate since the Region of Niagara requires that future sound level predictions be based on 20-year average daily traffic forecasts. A posted speed limit of 60 km/h was also applied in the analysis. Table II summarizes the traffic volume data used in this study.

Table II: Projected Road Traffic Data to the Year 2043

Road Name		Cars	Medium Trucks	Heavy Trucks	Total
Garrison Road	Daytime	26 013	392	627	27 032
	Nighttime	2 890	44	70	3 004
	Total	28 903	436	697	30 036

4.2 Traffic Noise Predictions

To assess the levels of road traffic noise which will impact the study area in the future, sound level predictions were made using STAMSON version 5.04. Sample STAMSON output is included in Appendix B.

Figure 2 shows the site plan with prediction locations. The results of these predictions are summarized in Table III. Sound levels were predicted at the plane of the top storey windows of the proposed buildings during daytime and nighttime hours to investigate ventilation requirements.

Table III: Daytime and Nighttime Predicted Future Sound Levels [dBA], Without Mitigation

Prediction Location	Description	Daytime – at the Façade L _{EQ-16 hr}	Nighttime – at the Façade L _{EQ-8 hr}
A	Block A – North Façade	69	63
	Rooftop Amenity Area	<55	--
B	Block A – West Façade	64	57
C	Block B – North Façade	58	52
D	Block B – West Façade	55	<50
E	Block B – Rear Yard at west of building	<55	--

5 Traffic Noise Recommendations

The predictions indicate that the future traffic sound levels at the proposed buildings will exceed MECP guidelines. Recommendations for noise control measures to address these excesses are discussed below.

5.1 Outdoor Living Areas

Block A includes rooftop terraces that are larger than 4 m in depth. A sound level prediction indicates a sound level of less than 55 dBA with the inclusion of a solid 1.07 m parapet. Further mitigation is not required.

The predicted daytime sound levels in the rear yards of the residential units (prediction location [E]) will not exceed the MECPs guideline of 55 dBA. Physical mitigation will not be required in these rear yards.

Any balconies or terraces with depths less than 4 m are not considered as outdoor living areas (OLAs) and therefore do not require a traffic noise assessment.

Common amenity areas were not indicated on the site plan.

5.2 Indoor Living Areas & Ventilation Requirements

Central Air Conditioning

The predicted daytime sound level at the north facade of units in Block A (Prediction Location [A]) will be greater than 65 dBA and greater than 60 dBA during the nighttime hours. To address these excesses, the MECP guidelines recommend that the proposed building be equipped with central air conditioning systems, so that the windows can be closed. This building is indicated in Figure 3.

The guidelines also recommend warning clauses for these dwelling units. Window or through-the-wall air conditioning units are not recommended for any residential units because of the noise they produce and because the units penetrate through the exterior wall which degrades the overall noise insulating properties of the envelope. Suitable units may be housed in their own closet with an access door for maintenance. The location, installation and sound ratings of the outdoor air conditioning devices should minimize noise impacts and comply with criteria of MECP publication NPC-300.

Provision for Central Air Conditioning

Blocks B and C have predicted nighttime sound levels in the range of 51 to 60 dBA and daytime levels in the range of 56 to 65 dBA. These dwelling units require the provision for the future installation of central air conditioning systems. This requirement is typically satisfied through the installation of forced air ventilation systems with ductwork sized for the future installation of central air conditioning by the occupant. The use of central air conditioning will exceed this requirement. This building is indicated in Figure 3.

The guidelines also recommend warning clauses for these dwelling units.

There are no specific ventilation requirements for Block D.

5.3 Building Façade Constructions

Future road traffic sound levels at the north facade of units in Block A (Prediction Location [A]) will be greater than 65 dBA during the daytime and greater than 60 dBA during the nighttime. MECP guidelines recommend that the windows, walls and doors be designed so that the indoor sound levels comply with MECP noise criteria.

Calculations were performed to determine the acoustical insulation factors to maintain indoor sound levels within MECP guidelines. The calculation methods were developed by the National Research Council (NRC). They are based on the predicted future sound levels at the building facades, and the anticipated area ratios of the facade components (walls, windows and doors) and the floor area of the adjacent room.

Acoustical Requirements for Glazing

A summary of the sound transmission class (STC) requirements is given in Table IV for the building façades, based on the possibility of sound entering the building through windows, doors, and walls. Preliminary floor plans and building elevations prepared by Organica Studio+ dated September 19, 2023 were used in the analysis. Bedrooms facing Garrison Road have a window to floor ratio of up to 13% of the floor area and living/dining rooms have up to 47% of the floor area. Preliminary window STC ratings required to mitigate road traffic noise levels are provided below.

Table IV: Minimum STC Requirements

Description	Space	Minimum STC Glazing Requirements
Block A	Living/Dining	STC-30
	Bedroom	STC-30
Blocks B, C, D	All rooms	OBC

The glazing requirements can be met using fairly standard sealed units. Operable sections, including doors and operable windows, must be well-fitted and weather-stripped in order to achieve the upper range of target STC values. Acoustical criteria for different facades can be optimized as part of the detail design of the development, when floor plans and elevations for the buildings are available.

Sample window assemblies which may achieve the STC requirements are summarized in Table V below. Note that acoustic performance varies with manufacturer’s construction details, and these are only guidelines to provide some indication of the type of glazing likely to be required; the STC requirements in Table IV are provided as a guideline based on the preliminary drawings. Acoustical

test data for the selected assemblies should be requested from the supplier, to ensure that the stated acoustic performance levels will be achieved by their assemblies.

Table V: Glazing Assemblies for STC Requirements

STC Requirement	Glazing Configuration (STC)
28 – 29	Any double glazed unit
30 – 31	3(13)3

In Table V, the number outside parentheses indicate minimum pane thicknesses in millimeters and the number in parentheses indicates the minimum inter-pane gap in millimeters.

Alternative assemblies may be required for operable windows and doors to achieve the required performance values, depending on the nature of seals.

Further Analysis

When detailed floor plans and building elevations (including operable and fixed sections of windows) are available for the dwelling units in Block A, window glazing construction should be refined based on actual window to floor area ratios.

6 Warning Clauses

The MECP guidelines recommend that warning clauses be included in the property and tenancy agreements and offers of purchase and sale for proposed buildings with anticipated traffic sound level excesses and to inform them of existing/proposed institutional and commercial uses nearby. The following noise warning clauses are required.

Suggested wording for future dwellings with sound level excesses is given below.

Type A:

Purchasers/tenants are advised that despite the inclusion of noise control features in the development and within the building units, sound levels due to increasing road traffic may occasionally interfere with some activities of the dwelling occupants as the sound levels exceed the Municipality's and the Ministry of the Environment, Conservation and Parks' noise criteria.

Suitable wording for future dwellings requiring central air conditioning systems is given below.

Type B:

This dwelling unit has been supplied with a central air conditioning system which will allow windows and exterior doors to remain closed, thereby ensuring that the indoor sound levels are within the Municipality's and the Ministry of Environment, Conservation and Parks' noise criteria.

Suitable wording for future dwellings requiring forced air ventilation systems is given below.

Type C:

This dwelling unit has been fitted with a forced air heating system and the ducting etc., was sized to accommodate central air conditioning. Installation of central air conditioning will allow windows and exterior doors to remain closed, thereby ensuring that the indoor sound levels are within the noise criteria of the Municipality and the Ministry of the Environment, Conservation and Parks. (Note: The location and installation of the outdoor air conditioning device should be done so as to minimize the noise impacts and comply with criteria of MECP publication NPC-216, Residential Air Conditioning Devices.)

Suggested wording for future dwelling units in close proximity to commercial and institutional uses is given below.

Type D:

Purchasers are advised that due to the proximity to existing commercial and institutional uses, sound levels from the facilities may be at times be audible.

These sample clauses are provided by the MECP as examples and can be modified by the Municipality as required.

7 Summary & Recommendations

The following list and Table VI summarize the recommendations made in this report. The reader is referred to the previous sections of the report where these recommendations are applied and discussed in more detail.

1. Central air conditioning will be required for units in Block A. Forced air ventilation systems with ductwork sized for the future installation of central air conditioning by the occupant or an alternative means of ventilation to open windows will be required for Blocks B and C. The

location, installation and sound ratings of the air conditioning devices should comply with NPC-300.

2. Upgraded building constructions are required for the north façade of Block A as noted in Section 5.3. When detailed floor plans and building elevations are available for the dwelling units with exposure to the roadway, window glazing construction should be refined on actual window to floor ratios. Building constructions meeting the minimum requirements of the Ontario Building Code will be sufficient for the remaining buildings in the development.
3. The use of warning clauses in the property and tenancy agreements is recommended to inform future residents of traffic noise issues and of the proximity to existing commercial and institutional uses.

Table VI: Summary of Noise Control Requirements and Noise Warning Clauses

Description	Ventilation Requirements*	Type of Warning Clause	Upgraded Glazing Constructions**
Block A	Central A/C	A, B, D	LR/DR: STC-30 BR: STC-30
Blocks B, C	Forced Air	A, C, D	LR/DR: OBC BR: OBC
Block D	--	D	OBC

Notes:

* The location, installation and sound rating of the air conditioning condensers must be compliant with MECP Guideline NPC-300, as applicable.

** When detailed floor plans and elevations are available, glazing construction requirements should be refined.

OBC – Ontario Building Code

LR/DR – Living Room/Dining Room

BR – Bedroom

7.1 Implementation

To ensure that the noise control recommendations outlined above are properly implemented, it is recommended that:

1. Prior to the issuance of building permits for this development, a Professional Engineer qualified to perform acoustical engineering services in the Province of Ontario should review

the detailed architectural plans and building elevations to refine glazing requirements for Building A based on actual window to floor areas ratios.

2. Prior to the issuance of occupancy permits for this development, the Municipality's building inspector or a Professional Engineer qualified to perform acoustical engineering services in the Province of Ontario should certify that the noise control measures have been properly incorporated, installed, and constructed.



ACOUSTICS



NOISE



VIBRATION



Figure 1: Key Plan

Appendix A

Road Traffic Data



ACOUSTICS



NOISE



VIBRATION

Location..... Garrison Road @ Pettit Road / Daytona Drive

GeoID..... 01681

Municipality. FORT ERIE

Count Date. Thursday, 23 May, 2019

Traffic Cont.

Count Time. 07:00 AM — 09:00 AM

Major Dir..... East west

Peak Hour.. 07:45 AM — 08:45 AM

Cyclists

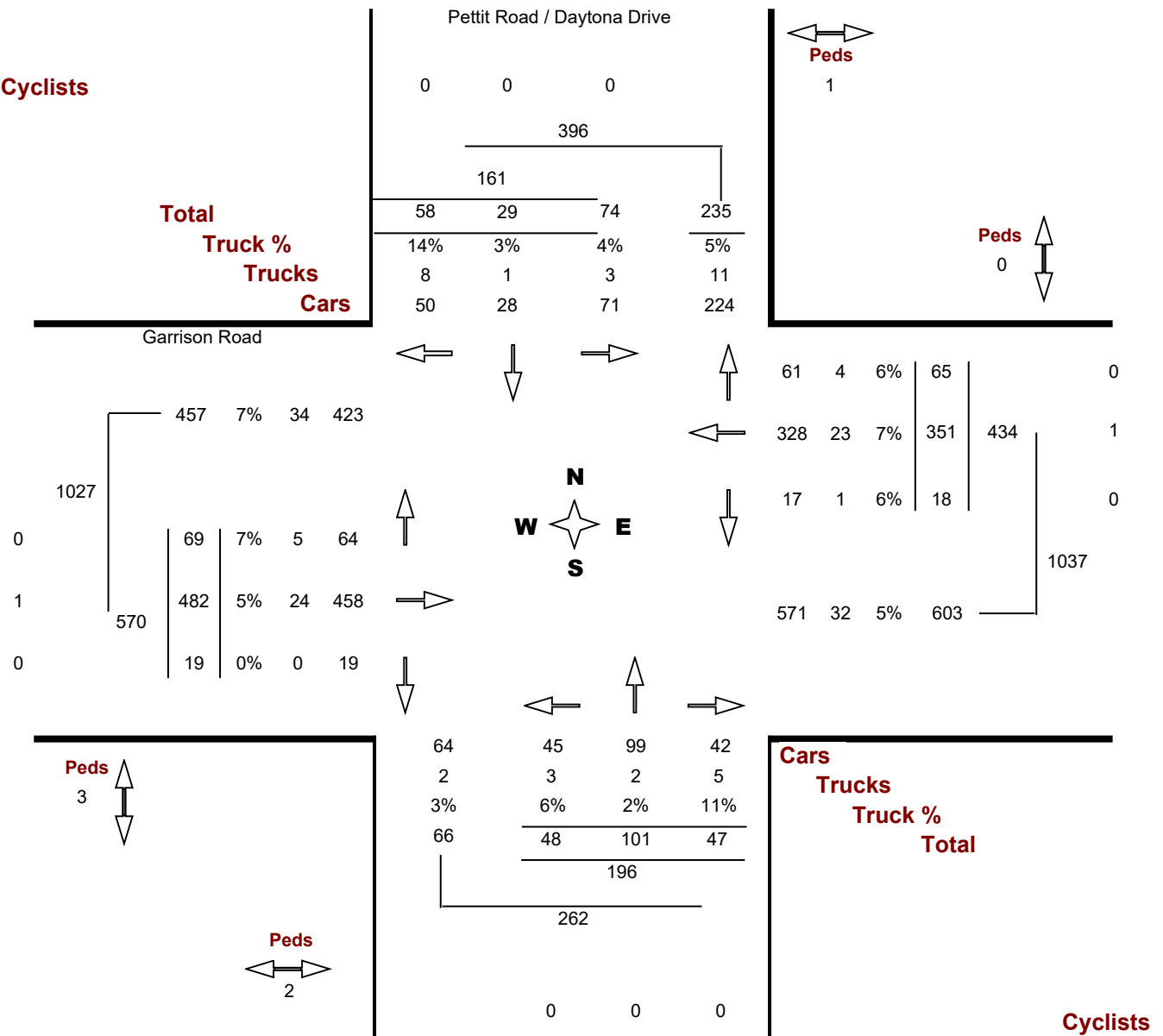

Location..... Garrison Road @ Pettit Road / Daytona Drive

GeoID..... 01681

Municipality. FORT ERIE

Count Date. Thursday, 23 May, 2019

Traffic Cont.

Count Time. 03:00 PM — 06:00 PM

Major Dir..... East west

Peak Hour.. 03:30 PM — 04:30 PM

Cyclists

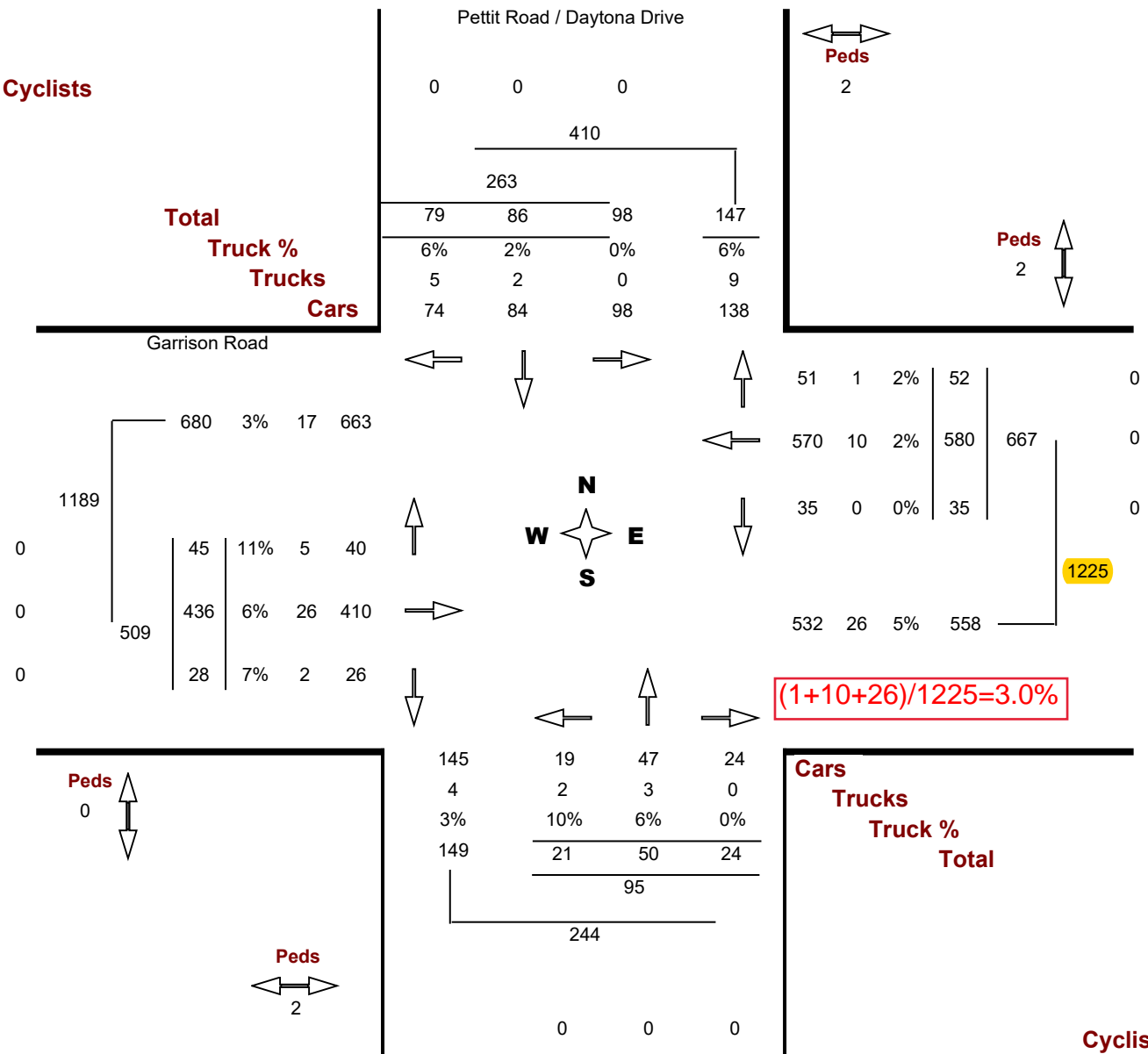

Location..... Garrison Road @ Pettit Road / Daytona Drive

Municipality..... FORT ERIE

GeoID..... 01681

Count Date..... Thursday, 23 May, 2019

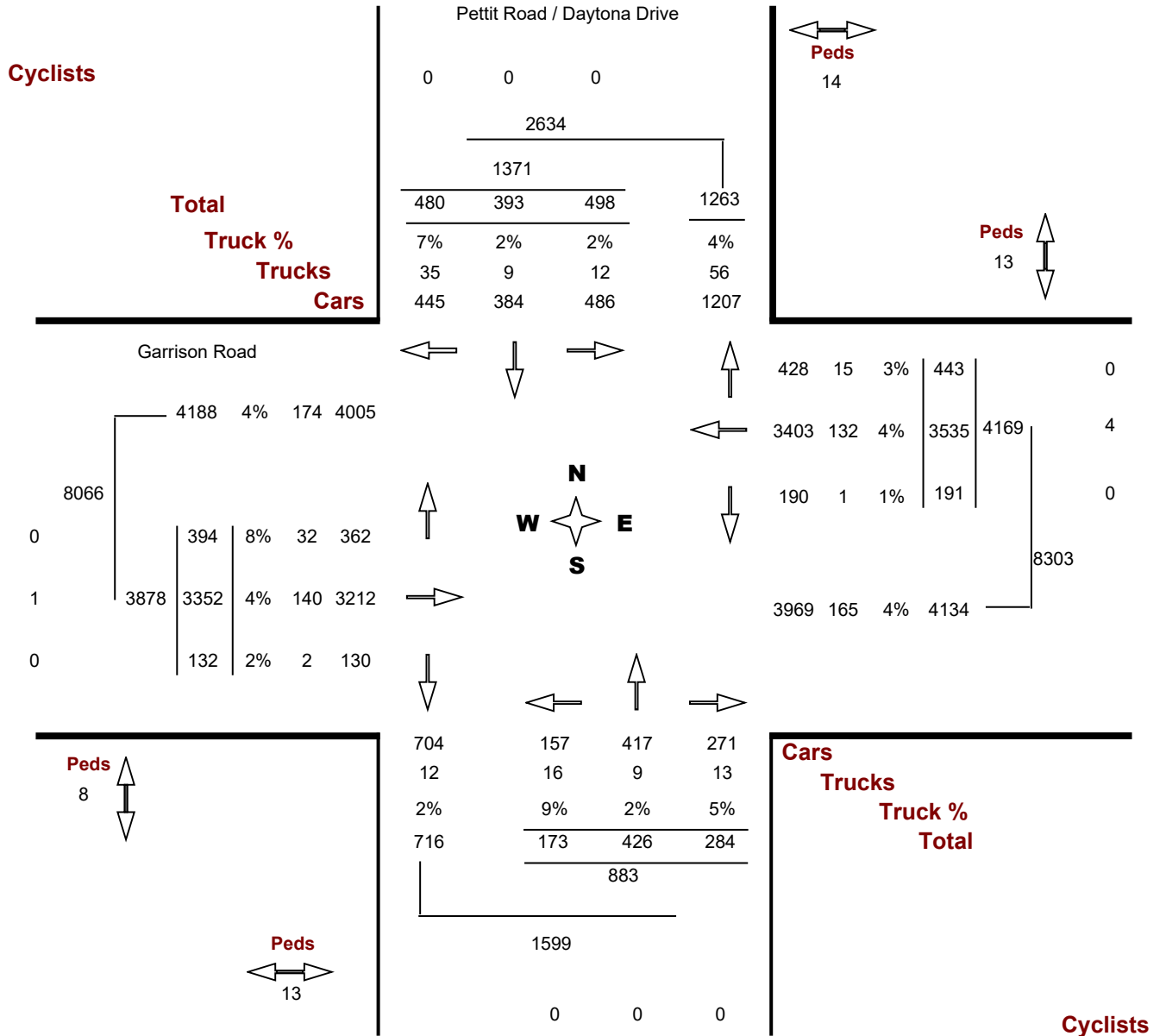

Turning Movement Count - Details Report (15 min)

Location..... Garrison Road @ Pettit Road / Daytona Drive

Municipality..... FORT ERIE

Count Date..... Thursday, May 23, 2019

Pettit Road / Daytona Drive

Garrison Road

North Approach

South Approach

East Approach

West Approach

Time Period	LT	TH	RT	U-Turn	TOT	LT	TH	RT	U-Turn	TOT	LT	TH	RT	U-Turn	TOT	LT	TH	RT	U-Turn	TOT
07:00 07:15	6	3	10	0	19	2	13	6	0	21	2	42	12	0	56	14	57	1	0	72
07:15 07:30	5	1	5	0	11	7	19	7	0	33	0	45	22	0	67	12	74	2	0	88
07:30 07:45	11	2	16	0	29	7	13	11	0	31	0	56	20	0	76	15	72	2	0	89
07:45 08:00	18	7	14	0	39	11	25	8	0	44	2	87	12	0	101	18	132	4	0	154
Hourly Total	40	13	45	0	98	27	70	32	0	129	4	230	66	0	300	59	335	9	0	403
08:00 08:15	19	5	15	0	39	13	32	7	0	52	5	82	18	0	105	14	103	5	0	122
08:15 08:30	16	9	16	0	41	12	21	15	0	48	5	89	18	0	112	23	129	6	0	158
08:30 08:45	21	8	13	0	42	12	23	17	0	52	6	93	17	0	116	14	118	4	0	136
08:45 09:00	13	11	6	0	30	6	22	18	0	46	4	75	9	0	88	13	145	4	0	162
Hourly Total	69	33	50	0	152	43	98	57	0	198	20	339	62	0	421	64	495	19	0	578
11:00 11:15	15	7	13	0	35	4	6	5	0	15	5	98	11	0	114	10	82	2	0	94
11:15 11:30	14	8	12	0	34	0	6	7	0	13	10	115	9	0	134	20	90	4	0	114
11:30 11:45	17	5	12	0	34	8	12	9	0	29	3	97	15	0	115	6	102	5	0	113
11:45 12:00	12	4	10	0	26	6	7	11	0	24	2	128	14	0	144	13	114	3	0	130
Hourly Total	58	24	47	0	129	18	31	32	0	81	20	438	49	0	507	49	388	14	0	451
12:00 12:15	13	10	16	0	39	1	9	8	0	18	7	141	12	0	160	8	119	4	0	131
12:15 12:30	11	9	14	0	34	4	7	6	0	17	8	94	17	0	119	13	105	3	0	121
12:30 12:45	14	9	10	0	33	1	9	6	0	16	6	106	16	0	128	7	131	3	0	141
12:45 13:00	10	7	8	0	25	3	4	5	0	12	10	76	12	0	98	9	130	1	0	140
Hourly Total	48	35	48	0	131	9	29	25	0	63	31	417	57	0	505	37	485	11	0	533
13:00 13:15	18	7	12	0	37	7	10	14	0	31	8	92	13	0	113	9	99	0	0	108
13:15 13:30	11	11	13	0	35	3	13	9	0	25	1	107	11	0	119	15	113	1	0	129
13:30 13:45	7	12	8	0	27	6	10	6	0	22	6	113	13	0	132	9	116	2	0	127
13:45 14:00	15	10	12	0	37	8	12	6	0	26	5	119	9	0	133	9	97	2	0	108
Hourly Total	51	40	45	0	136	24	45	35	0	104	20	431	46	0	497	42	425	5	0	472
15:00 15:15	16	25	25	0	66	4	14	12	0	30	6	131	13	0	150	10	85	8	0	103
15:15 15:30	11	14	6	0	31	8	21	17	0	46	9	142	13	0	164	9	98	3	0	110
15:30 15:45	25	26	31	0	82	6	14	7	0	27	6	133	14	0	153	9	104	8	0	121
15:45 16:00	30	23	20	0	73	6	12	5	0	23	12	123	13	0	148	10	120	11	0	141
Hourly Total	82	88	82	0	252	24	61	41	0	126	33	529	53	0	615	38	407	30	0	475
16:00 16:15	25	22	16	0	63	4	15	5	0	24	8	147	18	0	173	17	104	3	0	124

Pettit Road / Daytona Drive

Garrison Road

Time Period	North Approach					South Approach					East Approach					West Approach				
	LT	TH	RT	U-Turn	TOT	LT	TH	RT	U-Turn	TOT	LT	TH	RT	U-Turn	TOT	LT	TH	RT	U-Turn	TOT
16:15 16:30	18	15	12	0	45	5	9	7	0	21	9	177	7	0	193	9	108	6	0	123
16:30 16:45	13	22	23	0	58	3	14	4	0	21	5	151	25	0	181	15	97	6	0	118
16:45 17:00	17	16	15	0	48	3	13	12	0	28	8	136	11	0	155	12	95	3	0	110
Hourly Total	73	75	66	0	214	15	51	28	0	94	30	611	61	0	702	53	404	18	0	475
17:00 17:15	19	29	18	0	66	4	12	6	0	22	10	145	17	0	172	17	109	12	0	138
17:15 17:30	23	20	20	0	63	4	10	4	0	18	10	150	9	0	169	8	97	5	0	110
17:30 17:45	18	22	26	0	66	3	11	9	0	23	6	123	9	0	138	18	94	6	0	118
17:45 18:00	17	14	33	0	64	2	8	15	0	25	7	122	14	0	143	9	113	3	0	125
Hourly Total	77	85	97	0	259	13	41	34	0	88	33	540	49	0	622	52	413	26	0	491
Grand Total	498	393	480	0	1371	173	426	284	0	883	191	3535	443	0	4169	394	3352	132	0	3878
Truck %	2%	2%	7%	0%	4%	9%	2%	5%	0%	4%	1%	4%	3%	0%	4%	8%	4%	2%	0%	4%

Appendix B

Sample STAMSON 5.04 Output



ACOUSTICS



NOISE



VIBRATION

Filename: a.te Time Period: Day/Night 16/8 hours
 Description: Block A- North Façade- Top Storey- PREDICTION LOCATION "A"

Road data, segment # 1: Garrison (day/night)

 Car traffic volume : 26013/2890 veh/TimePeriod *
 Medium truck volume : 392/44 veh/TimePeriod *
 Heavy truck volume : 627/70 veh/TimePeriod *
 Posted speed limit : 60 km/h
 Road gradient : 0 %
 Road pavement : 1 (Typical asphalt or concrete)

* Refers to calculated road volumes based on the following input:

24 hr Traffic Volume (AADT or SADT): 16606
 Percentage of Annual Growth : 2.50
 Number of Years of Growth : 24.00
 Medium Truck % of Total Volume : 1.45
 Heavy Truck % of Total Volume : 2.32
 Day (16 hrs) % of Total volume : 90.00

Data for Segment # 1: Garrison (day/night)

 Angle1 Angle2 : -90.00 deg 90.00 deg
 Wood depth : 0 (No woods.)
 No of house rows : 0 / 0
 Surface : 2 (Reflective ground surface)
 Receiver source distance : 18.00 / 18.00 m
 Receiver height : 9.50 / 9.50 m
 Topography : 1 (Flat/gentle slope; no barrier)
 Reference angle : 0.00

Results segment # 1: Garrison (day)

 Source height = 1.23 m

ROAD (0.00 + 69.42 + 0.00) = 69.42 dBA

Angle1	Angle2	Alpha	RefLeq	P.Adj	D.Adj	F.Adj	w.Adj	H.Adj	B.Adj	SubLeq
-90	90	0.00	70.21	0.00	-0.79	0.00	0.00	0.00	0.00	69.42

Segment Leq : 69.42 dBA

Total Leq All Segments: 69.42 dBA

Results segment # 1: Garrison (night)

 Source height = 1.24 m

ROAD (0.00 + 62.90 + 0.00) = 62.90 dBA

Angle1	Angle2	Alpha	RefLeq	P.Adj	D.Adj	F.Adj	w.Adj	H.Adj	B.Adj	SubLeq
-90	90	0.00	63.69	0.00	-0.79	0.00	0.00	0.00	0.00	62.90

Segment Leq : 62.90 dBA

Total Leq All Segments: 62.90 dBA

TOTAL Leq FROM ALL SOURCES (DAY): 69.42
 (NIGHT): 62.90

Road data, segment # 3: Garrison (day/night)

```

-----
Car traffic volume : 26013/2890 veh/TimePeriod *
Medium truck volume : 392/44 veh/TimePeriod *
Heavy truck volume : 627/70 veh/TimePeriod *
Posted speed limit : 60 km/h
Road gradient : 0 %
Road pavement : 1 (Typical asphalt or concrete)
    
```

* Refers to calculated road volumes based on the following input:

```

24 hr Traffic volume (AADT or SADT): 16606
Percentage of Annual Growth : 2.50
Number of Years of Growth : 24.00
Medium Truck % of Total Volume : 1.45
Heavy Truck % of Total Volume : 2.32
Day (16 hrs) % of Total Volume : 90.00
    
```

Data for Segment # 3: Garrison (day/night)

```

-----
Angle1 Angle2 : 22.00 deg 90.00 deg
Wood depth : 0 (No woods.)
No of house rows : 0 / 0
Surface : 1 (Absorptive ground surface)
Receiver source distance : 74.00 / 74.00 m
Receiver height : 11.50 / 11.50 m
Topography : 1 (Flat/gentle slope; no barrier)
Reference angle : 0.00
    
```

Results segment # 1: Garrison (day)

Source height = 1.23 m

```

ROAD (0.00 + 55.26 + 0.00) = 55.26 dBA
Angle1 Angle2 Alpha RefLeq P.Adj D.Adj F.Adj w.Adj H.Adj B.Adj SubLeq
-----
-90 -22 0.37 70.21 0.00 -9.48 -5.47 0.00 0.00 0.00 55.26
-----
    
```

Segment Leq : 55.26 dBA

Results segment # 2: Building (day)

Source height = 1.23 m

Barrier height for grazing incidence

```

-----
Source ! Receiver ! Barrier ! Elevation of
Height (m) ! Height (m) ! Height (m) ! Barrier Top (m)
-----
1.23 ! 11.50 ! 3.73 ! 3.73
-----
    
```

```

ROAD (0.00 + 37.20 + 0.00) = 37.20 dBA
Angle1 Angle2 Alpha RefLeq P.Adj D.Adj F.Adj w.Adj H.Adj B.Adj SubLeq
-----
-22 22 0.00 70.21 0.00 -6.93 -6.12 0.00 0.00 -19.96 37.20
-----
    
```

Segment Leq : 37.20 dBA

Results segment # 3: Garrison (day)

Source height = 1.23 m

```

ROAD (0.00 + 55.26 + 0.00) = 55.26 dBA
Angle1 Angle2 Alpha RefLeq P.Adj D.Adj F.Adj w.Adj H.Adj B.Adj SubLeq
-----
22 90 0.37 70.21 0.00 -9.48 -5.47 0.00 0.00 0.00 55.26
-----
    
```

Segment Leq : 55.26 dBA

Total Leq All Segments: 58.30 dBA

Results segment # 1: Garrison (night)

Source height = 1.24 m

ROAD (0.00 + 48.74 + 0.00) = 48.74 dBA

Angle1	Angle2	Alpha	RefLeq	P.Adj	D.Adj	F.Adj	w.Adj	H.Adj	B.Adj	SubLeq
-90	-22	0.37	63.69	0.00	-9.48	-5.47	0.00	0.00	0.00	48.74

Segment Leq : 48.74 dBA

Results segment # 2: Building (night)

Source height = 1.24 m

Barrier height for grazing incidence

Source Height (m)	Receiver Height (m)	Barrier Height (m)	Elevation of Barrier Top (m)
1.24	11.50	3.73	3.73

ROAD (0.00 + 30.68 + 0.00) = 30.68 dBA

Angle1	Angle2	Alpha	RefLeq	P.Adj	D.Adj	F.Adj	w.Adj	H.Adj	B.Adj	SubLeq
-22	22	0.00	63.69	0.00	-6.93	-6.12	0.00	0.00	-19.96	30.68

Segment Leq : 30.68 dBA

Results segment # 3: Garrison (night)

Source height = 1.24 m

ROAD (0.00 + 48.74 + 0.00) = 48.74 dBA

Angle1	Angle2	Alpha	RefLeq	P.Adj	D.Adj	F.Adj	w.Adj	H.Adj	B.Adj	SubLeq
22	90	0.37	63.69	0.00	-9.48	-5.47	0.00	0.00	0.00	48.74

Segment Leq : 48.74 dBA

Total Leq All Segments: 51.78 dBA

TOTAL Leq FROM ALL SOURCES (DAY): 58.30
(NIGHT): 51.78

Appendix C

Supporting Drawings



ACOUSTICS



NOISE



VIBRATION

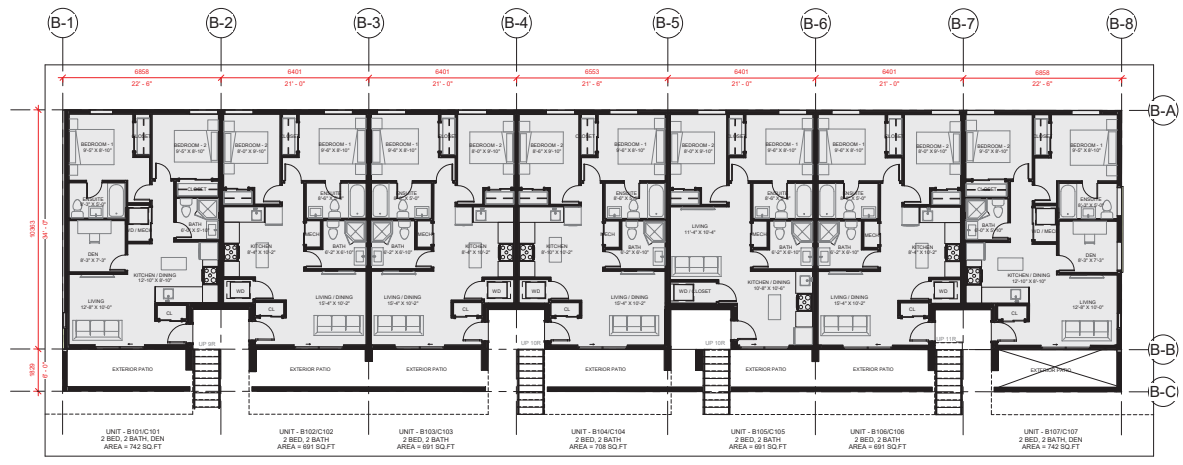

1 Block B & C - Lower Level
1:100

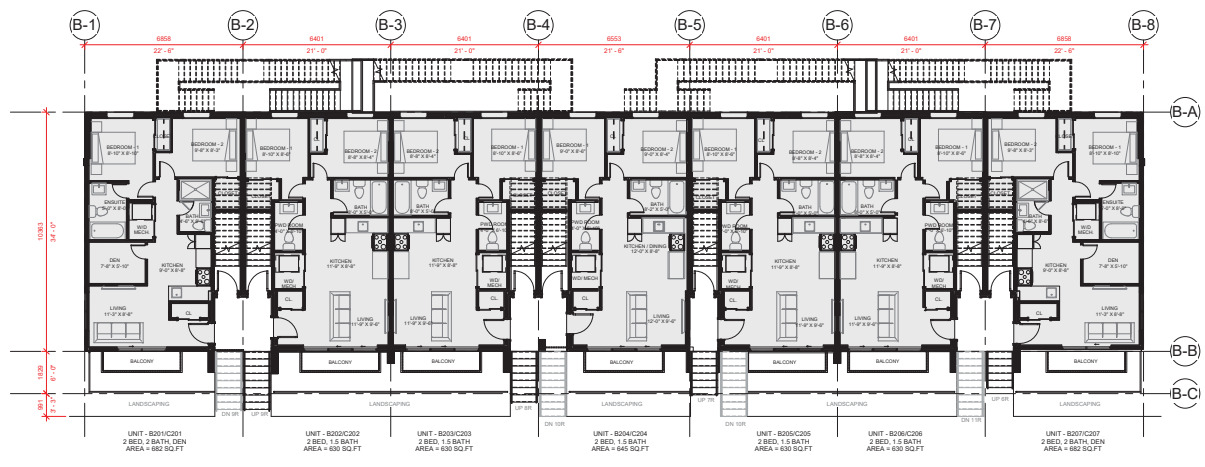

2 Block B & C - Ground Level
1:100

1.127 CARBON ROAD, TORONTO, ONTARIO M6H 2T9
 TEL: 416-291-1111 | WWW.ORGANICASTUDIO.COM
 © 2023 ORGANIC STUDIO + INC. ALL RIGHTS RESERVED.
 THIS DOCUMENT IS THE PROPERTY OF ORGANIC STUDIO + INC. AND IS NOT TO BE REPRODUCED OR TRANSMITTED IN ANY FORM OR BY ANY MEANS, ELECTRONIC OR MECHANICAL, WITHOUT THE WRITTEN PERMISSION OF ORGANIC STUDIO + INC.

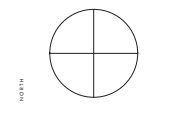

BLOCKS B & C - FLOOR PLANS

STACKED DWELLINGS

1.127 CARBON ROAD, TORONTO

SCALE	1:100
DATE	2023-09-19 11:02:41 AM
DRAWN	Adrian
CHECKED	Orlando
PROJECT NUMBER	21084
SHEET	A201

4/24/2024 10:03 AM - C:\Users\Adrian\OneDrive\Documents\1.127 Carbon Road\1.127 Carbon Road\2023\09\19\1.127 Carbon Road\Stacked Dwelling\21084_A201.dwg - Plotted from user: Adrian

4811 (rev. 0) - 03/2024
 10/2023
 2023/09/13 10:00 AM



1 Block A - North Elevation (Front)
1 : 100

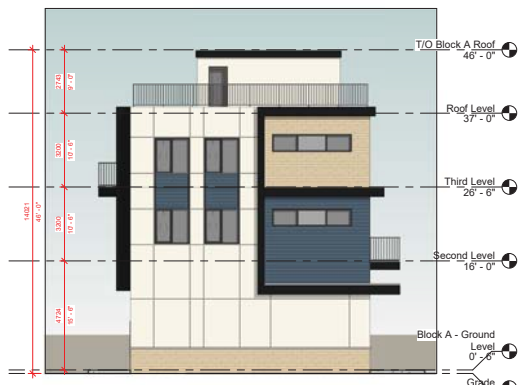

3 Block A - East Elevation (Left)
1 : 100



2 Block A - South Elevation (Rear)
1 : 100

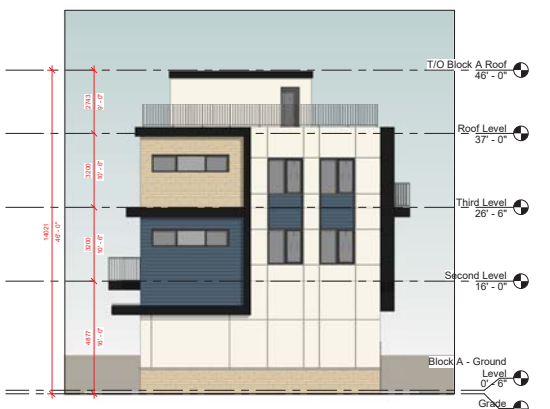

4 Block A - West Elevation (Right)
1 : 100

EXTERIOR FINISHES

HARDIE BOARD PANELS	HARDIE BOARD SIDING	HARDIE BOARD PANELS
BRICK VENEER	METAL PERGOLAS	

DOOR AND WINDOW LOCATION, DIMENSION, DETAILS, AND BUILDING MATERIALS MAY VARY DEPENDING ON FINAL INTERIOR UNIT LAYOUTS, AND ARE SHOWN FOR INFORMATION PURPOSES ONLY.



This drawing is the property of organica studio + inc. and is not to be reproduced, copied, or used in any way without the written consent of organica studio + inc. All rights reserved. The information contained herein is for informational purposes only and does not constitute an offer of any financial product or service. The information contained herein is subject to change without notice.

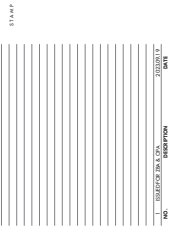
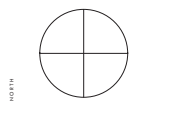

BLOCK A - ELEVATIONS
 STACKED DWELLINGS
 1127 CARRISON ROAD, FORT EBER

SCALE	As Indicated
DATE	2023-09-19 11:02:54 AM
DRAWN	Author
CHECKED	Order

PROJECT NUMBER 21084

SHEET A300

