

Shipping Containers Guidelines

Design option 3

Shed Roof

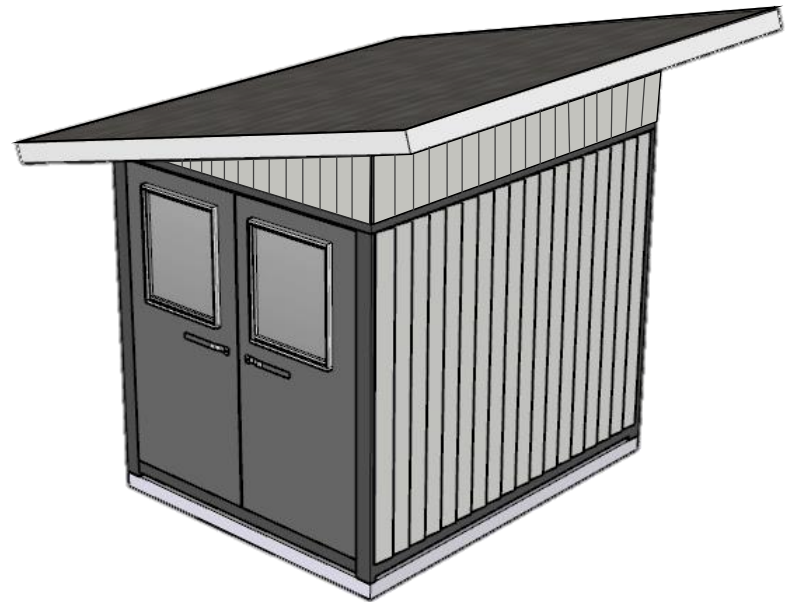

Residential zone set-backs (for Shipping Containers) :

General Guides:

- Accessory residential shipping container units shall be permitted in the rear yard or interior side yard and shall not be closer to any rear or interior side lot line than 1.0 m or closer to any exterior side yard than the required yard for dwellings.
- Shall only cover 10% (max.) of the land use
- Accessory residential shipping container units shall not exceed 3.7 m in height for flat roof and shall not exceed 4.5 m from grade to the peak with a pitched roof.
- Cannot be connected/attached to the main residential building
- All accessory shipping container units over 10 m² or 108 sq. ft. will require a building permit.
- All accessory shipping container units are subject to site plan control.

Allowed shipping container units :

- Must not have any holes or rips
- Must not be rusted, cracked or dented
- Must not be twisted
- Have not been used to transfer any dangerous goods.
- All accessory shipping containers must be vented
- All accessory shipping containers must contain at least one window.

(all notes mentioned above apply to 10', 20' shipping containers).

Optional Shipping Containers Configurations:

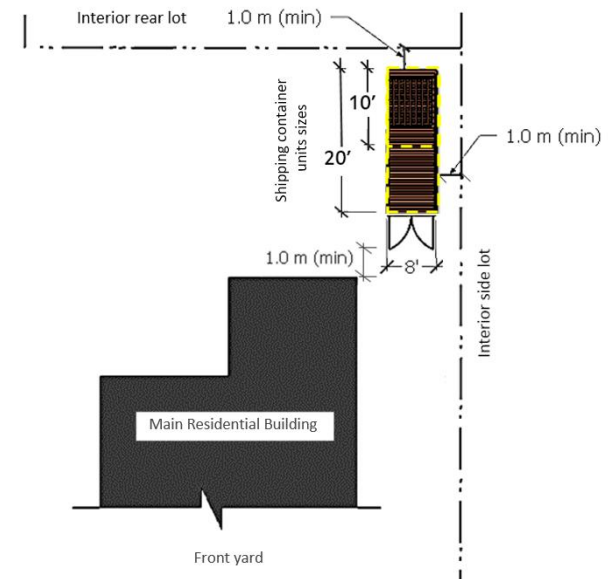

Shipping Container unit aligned with the side Lot line

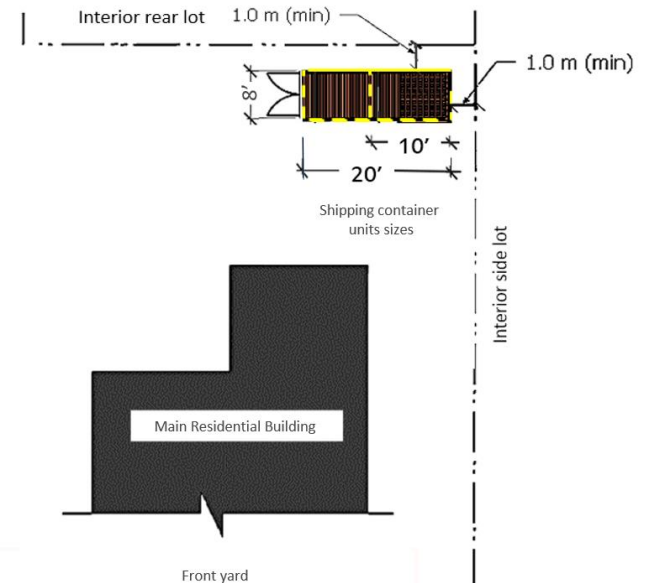

Shipping Container unit aligned with rear lot line

Design option 3

Shed Roof

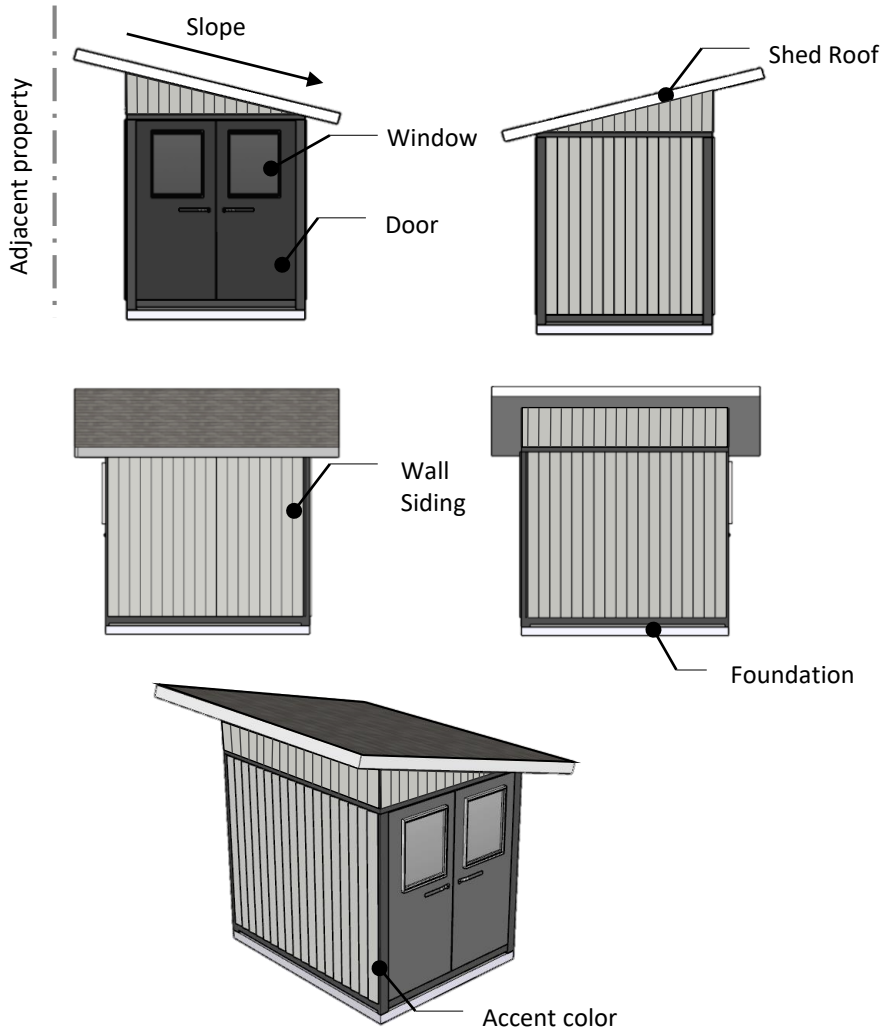

Slope should not be directed toward adjacent property

Wall sidings:

- Wood Siding (finished as per manufacturer's specs)
- Vinyl siding
- Fiber-cement Siding (finished as per manufacturer's specs)
- Aluminum Siding (finished as per manufacturer's specs)

Permitted to be installed vertically or horizontally (as per manufacturer's specs)

Color to be determined by owner.

Roof Finish:

- Asphalt shingles
 - Wood shakes and shingles
 - Metal Roofing
- (Solar panels to be applied separately if applicable)

Color to be determined by owner.

Optional roof vents (louvre vent, turbine vent ... Etc.)

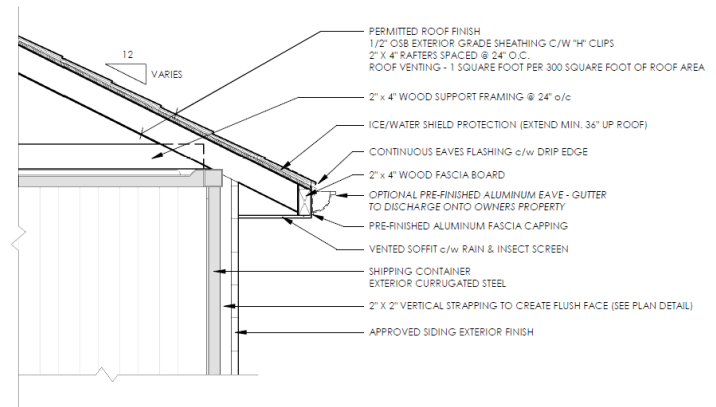

SHED / GABLE ROOF CONNECTION

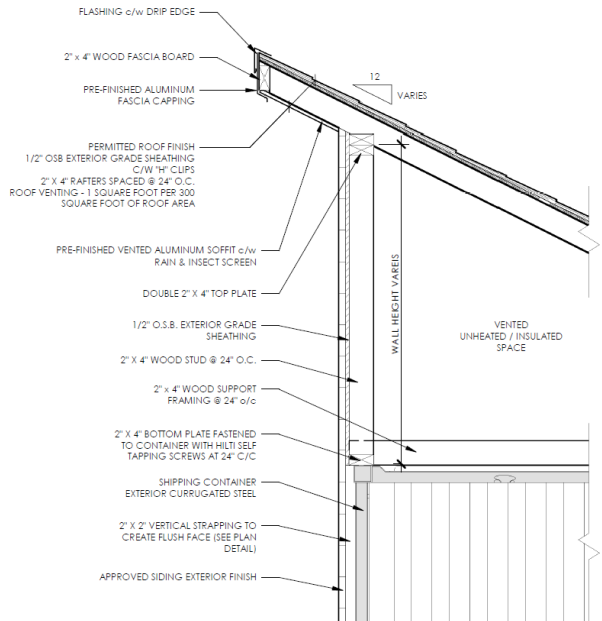

WALL SECTION DETAIL

Foundation Options:

- A. Concrete Pier
- B. Granular Base
- C. Concrete slab on grade
- D. Wood Sleepers (6x6 or 8x8)

Other foundation options to be submitted with required Eng. documents for building permit.

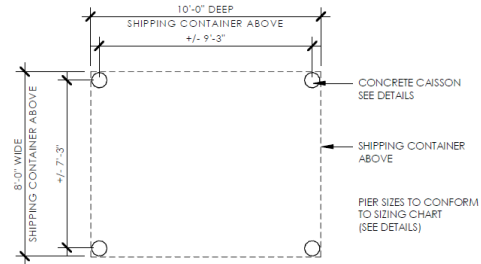

TYPE A - FOUNDATION PLAN - 10 FOOT CONTAINER

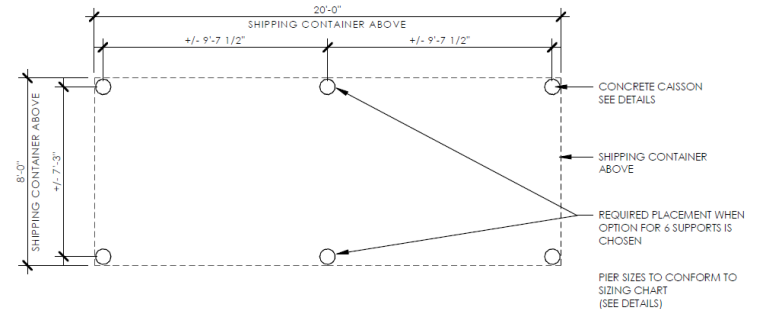

TYPE A - FOUNDATION PLAN - 20 FOOT CONTAINER

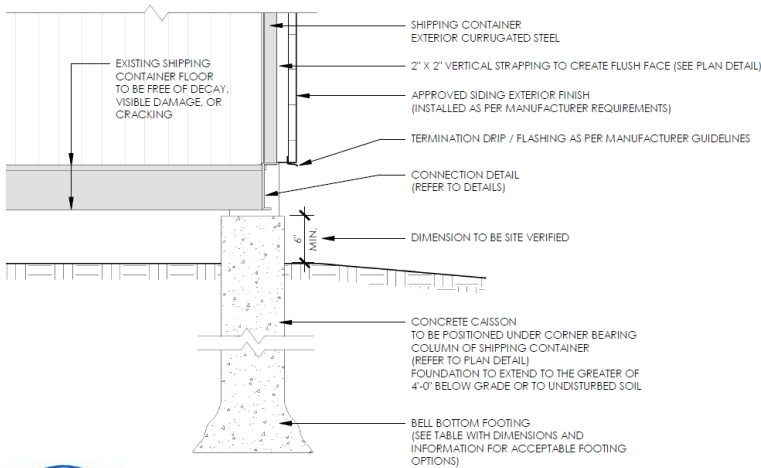

ALL FOOTINGS SHALL BEAR ON NATIVE SOIL WITH MINIMUM BEARING RESISTANCE OF 100 kPa, UNLESS NOTED OTHERWISE

ANY OVER EXCAVATED AREAS OR LOCAL SOFT AREAS OR POOR CONDITIONS SHALL BE MADE GOOD WITH LEAN CONCRETE FILL



© ENG STAMP FOR ITEMS AS NOTED ON PLANS. ALL ELSE BY OTHERS. ANY DEVIATIONS FROM PLANS NULLIFIES ENGINEERING

TYPE A - BASE DETAIL - CONCRETE PIER

APPLICABLE TO ALL DETAILS:

USE OF E70XX OR EQUIVALENT ELECTRODE FOR ALL WELDING, OR SUITABLE ELECTRODE FOR COR-TEN STEEL

ALL WELDING STEEL SHALL CONFORM TO THE REQUIREMENTS OF CSA STD. W59 AND SHALL BE UNDERTAKEN BY A FABRICATOR FULLY APPROVED BY THE CANADIAN WELDING BUREAU TO THE REQUIREMENTS OF CSA STD. W47

WELDING OF SHAPES TO SHIPPING CONTAINER SIZE SHALL BE FILLET WELDS ON EVERY SURFACE, FOR CORRUGATIONS PROVIDE ON EVERY OTHER (E.O.)

FILLET WELDS FOR HSS WITH RADIUS $\geq 10\text{mm}$ SHALL BE PROVIDED AS FLARE GROOVE WELDS IN ACCORDANCE TO CSA W59

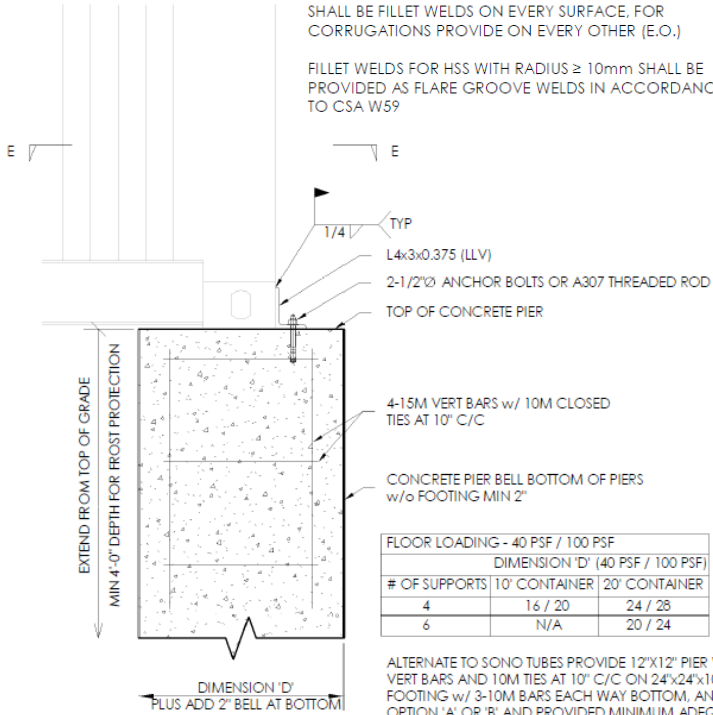

FLOOR LOADING - 40 PSF / 100 PSF		
DIMENSION 'D' (40 PSF / 100 PSF)		
# OF SUPPORTS	10' CONTAINER	20' CONTAINER
4	16 / 20	24 / 28
6	N/A	20 / 24

ALTERNATE TO SONO TUBES PROVIDE 12"x12" PIER W/ 4-15M VERT BARS AND 10M TIES AT 10" C/C ON 24"x24"x10" THK FOOTING w/ 3-10M BARS EACH WAY BOTTOM, ANCHORAGE OPTION 'A' OR 'B' AND PROVIDED MINIMUM ADEQUATE EDGE DISTANCE FOR ANCHORS

PIER SUPPORT - OPTION 'A'

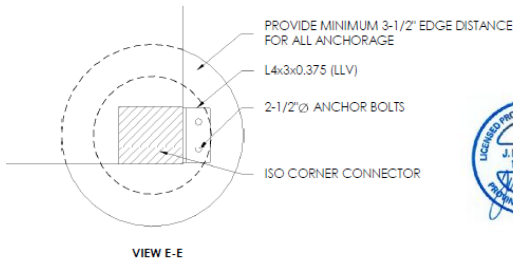

P/ENG STAMP FOR ITEMS AS NOTED ON PLANS. ALL ELSE BY OTHERS, ANY DEVIATIONS FROM PLANS NULLIFIES ENGINEERING

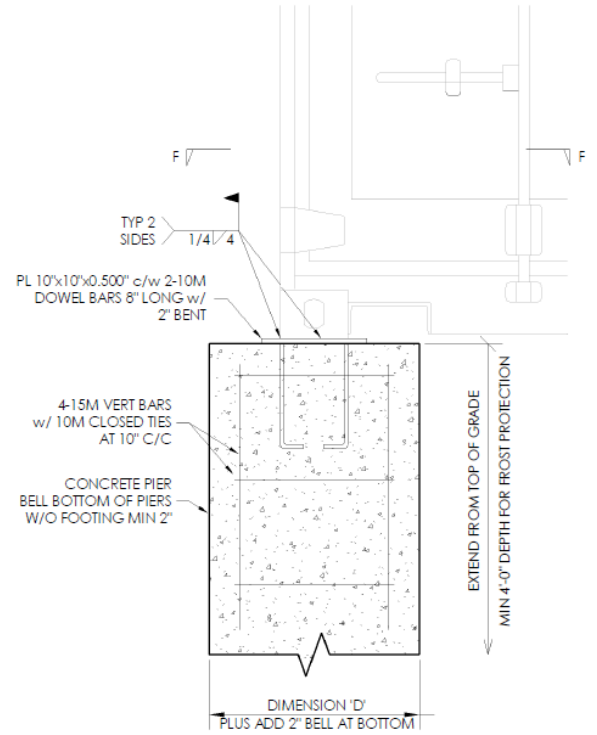

PIER SUPPORT - OPTION 'B'

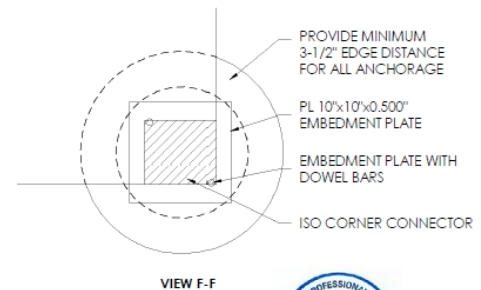

P/ENG STAMP FOR ITEMS AS NOTED ON PLANS. ALL ELSE BY OTHERS, ANY DEVIATIONS FROM PLANS NULLIFIES ENGINEERING

TYPE A - PIER ANCHOR DETAILS

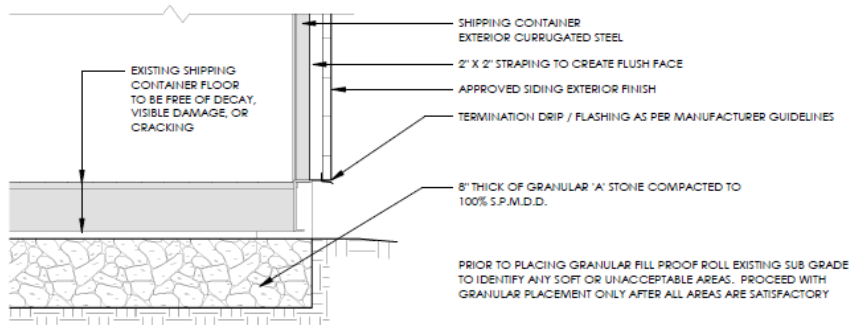

TYPE B - BASE DETAIL - ON GRADE

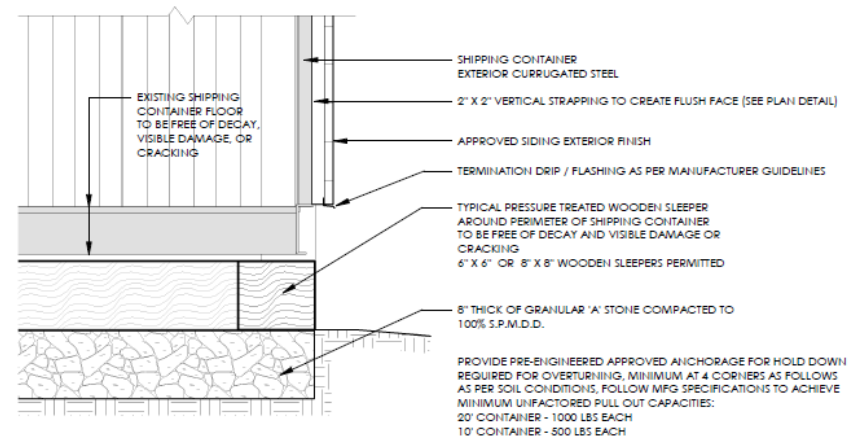

TYPE D - BASE DETAIL - WOOD SLEEPERS

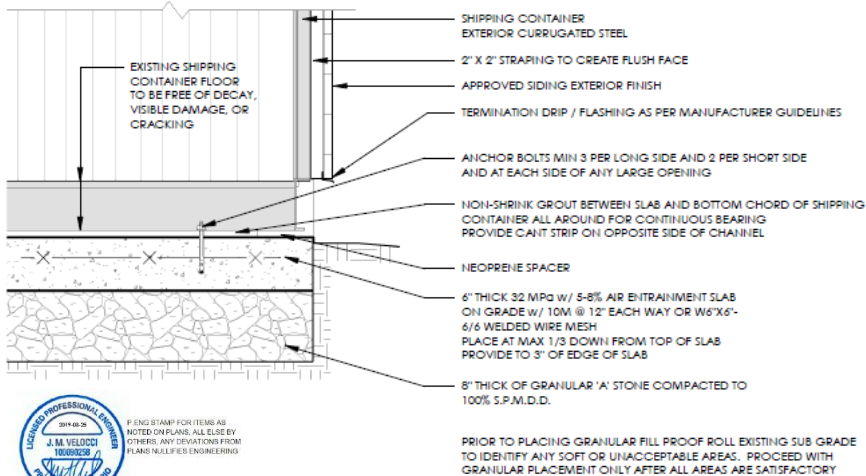

TYPE C - BASE DETAIL - SLAB ON GRADE

Doors and Windows

- All shipping container units (10' and 20') must be vented.
- Doors and windows materials to be determined by owner (wood, metal, aluminum, etc.)
- Type of door and window openings to be determined by owner (hinged doors, sliding doors, rotating, rolled doors, etc.), (casement Windows, awning window, slider windows, etc.)
- Side doors (double doors/single door) and side windows (fixed windows/casement window) are permitted to be facing inward of owner property boundary.

Example of a permitted design options:

20' shipping container existing metal doors (Same applied to 10' shipping containers units)

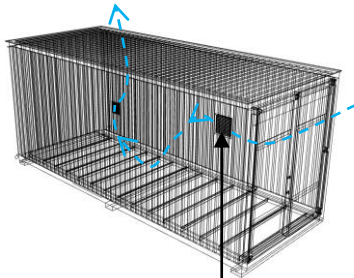

Example of round Louvre vent and air circulation

Doors and windows options:

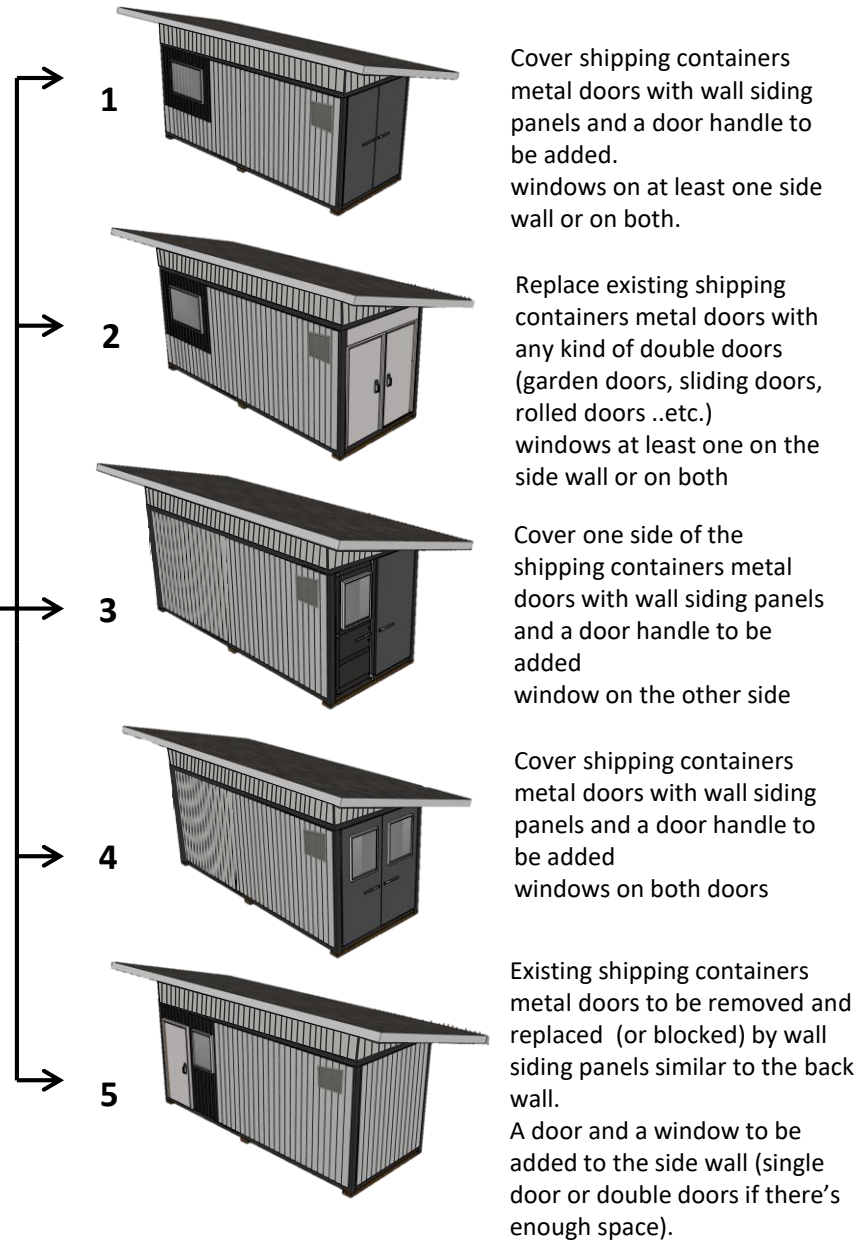

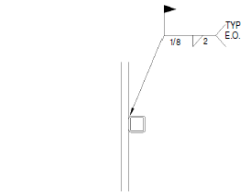

VIEW C-C
WALL VENT OPENING SECTION

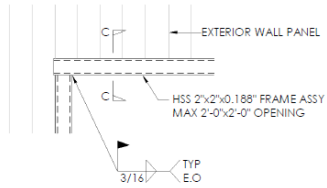

VIEW D-D
WALL VENT OPENING - ELEVATION VIEW

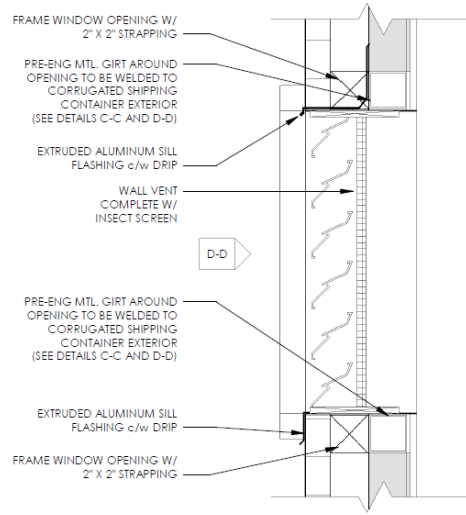

VENT OPENING DETAIL



P. ENG. STAMP FOR ITEMS AS NOTED ON PLANS. ALL ELSE BY OTHERS. ANY DEVIATIONS FROM PLANS NULLIFIES ENGINEERING

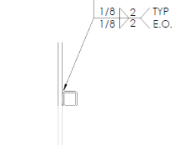

VIEW A-A
WINDOW OPENING SECTION

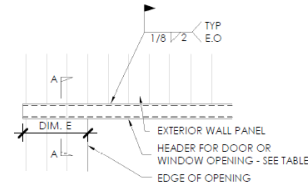

VIEW B-B
WINDOW OPENING ELEVATION VIEW

HEADER SIZES FOR WINDOW OR DOOR OPENINGS*		
OPENING SPAN	MEMBER SIZE	DIMENSION 'E'
2'-0" ≤ 4'-0"	HSS 2x2x0.188	6 INCHES
4'-0" ≤ 6'-0"	C3x5	12 INCHES
6'-0" ≤ 8'-0"	C4x5.4	12 INCHES

*BASED ON CLIMATIC LOADS FOR AREA PLUS 12PSF DEAD LOAD MAXIMUM FOR ROOF LOAD. ANY SPANS EXCEEDING 8'-0" OR INCREASED LOADING REQUIREMENTS SHALL BE DESIGNED SEPARATELY.

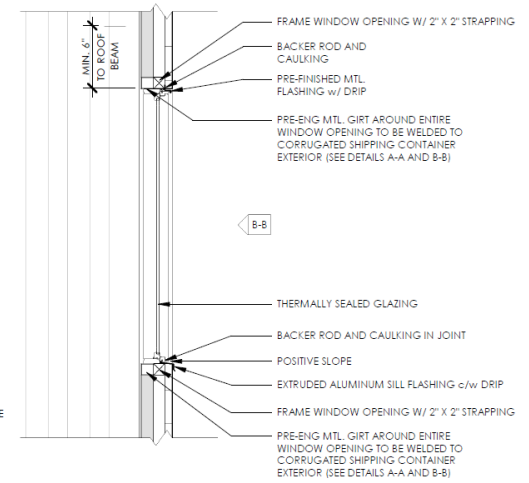

WINDOW OPENING SECTION



P. ENG. STAMP FOR ITEMS AS NOTED ON PLANS. ALL ELSE BY OTHERS. ANY DEVIATIONS FROM PLANS NULLIFIES ENGINEERING

Cladding coverage:

- 10' and 20' Shipping container units side walls to be 100% covered.
- The back wall of all shipping containers to be 100% covered.

Key Plan:

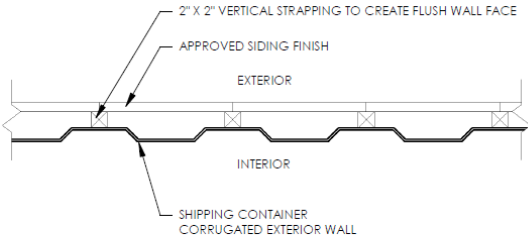
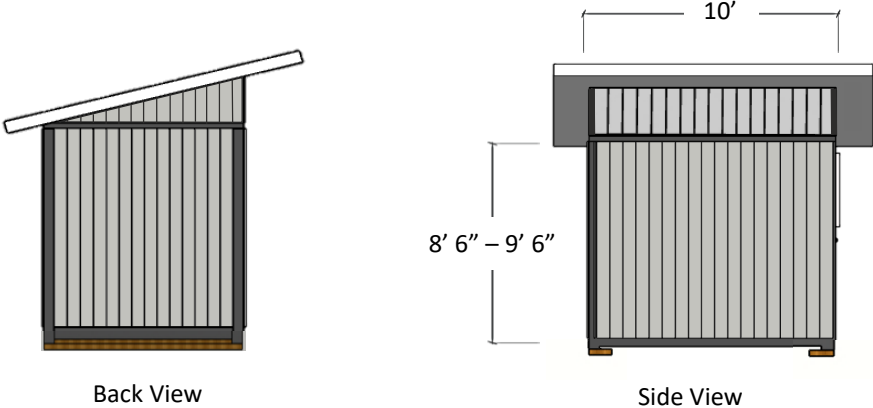
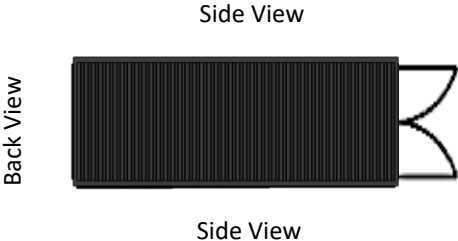

WALL STRAPPING PLAN DETAIL

